

Variable Speed Drives Save Energy and Costs in the Plastic Industry

DEVELOPMENT PARTNERS

Users: Tan Dai Hung Plastic, 373C Nguyen Son Street, Ward 18, Tan Binh District, Ho Chi Minh City, Vietnam.

Saigon Plastic, 50A Ben Phu Dinh, Ward 16, District 8, Ho Chi Minh City, Vietnam

Promoter: Department of Science, Technology and the Environment (DOSTE), 244 Dien Bien Phu, Ho Chi Minh City, Vietnam.

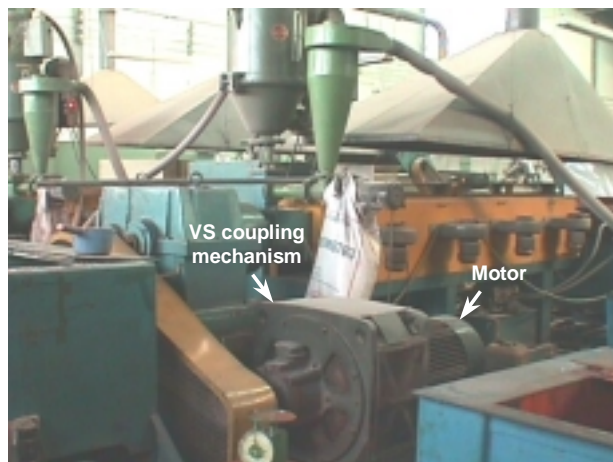

Electro-magnetic coupling-motor in an Extrusion molding machine

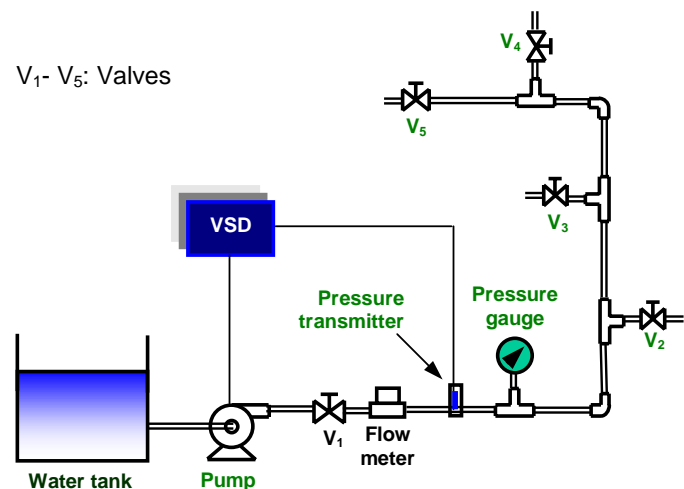

Demonstration to control cooling water flow rate by VSD in plastic industries

Summary

Variable speed drives (VSD) coupled to induction motors provide a reliable and cost effective solution to many applications including water pumping, fans, conveyors, etc. in plastic industries. In specific applications, a VSD can provide energy conservation benefits and improvements in operational control. Two examples, one for molding machines, and the other for cooling water supply are presented here.

Replacing a Variable Speed (VS) coupling mechanism by a Variable Speed Drive (VSD) in

an extrusion-molding machine has helped to reduce 28% of the total energy consumption for molding in Tan Dai Hung Plastic Company with a payback period of only 4.5 months.

In Saigon Plastic Company, the present cooling water system includes fixed speed pumps with by-pass valves to control the flow rate. It is estimated that by replacing all existing pumps by a single VSD-controlled pump, 85% of the energy consumption will be reduced. The payback period for this modification is estimated to be about 10 months.

The problem

Prime movers consume about 35% of the total energy consumption in plastic factories. Induction motors are commonly used in plastic forming industry, not only as prime movers in molding machines but also for water pumps, grinders, etc. For some applications, a change of speed is necessary. A motor supplies torque to the screw of extrusion molding machines through gearbox, VS coupling mechanism, DC motor or VSD-motor. These help adjust the speed of the screw coupled to the prime mover to match the specific need of each product.

Gearboxes are used in some old machines where average-to-low quality products are manufactured. They function efficiently but can only provide certain fixed speeds.

VS coupling mechanism can help in varying the speed over a wide range with acceptable accuracy, and is widely used. More than 50% of extrusion molding machines employ VS coupling mechanism for controlling the screw speed. However, this mechanism is inefficient since energy supplied in excess of what is required by the machine is lost as heat. This leads to an increased energy bill and higher ambient temperature in the working place. In this type of control, the higher the difference between the motor and the output speed, the greater is the power loss.

In cooling water systems for plastic molds and hydraulic oil, the water flow rate is varied by using a by-pass valve. This method is inefficient and increases the cost of pumps as well as the cooling tower system.

The answer

VSD can help adjust the prime mover speed to the required level and thus reduce energy losses. These units are currently available in the local market. The speed control in VSD is based on the following principle: the motor speed varies proportionally to the change of frequency of the power supplied to motor; the VSD allows to vary the frequency and obtain the desired output speed while assuring a reduction in the electricity cost.

PLASTIC INDUSTRY IN HCMC

- Plastic is considered as one of the key sectors of industrial development in Ho Chi Minh City. In 2000, about 900 enterprises were involved in making plastic products. The plastic sector has grown by 25–30% annually in recent years and is expected to maintain this growth in the coming years.
- However, lack of knowledge on resource conservation along with the increase in production has led to energy inefficiency and environment deterioration. Some options to improve the present situation are:
 - Housekeeping: measuring and recording production data and energy use; regular checking and maintenance of equipment.
 - Improved working condition: insulating heating sources, reducing noise, etc.
 - Energy saving options: insulation to reduce heat loss, replacement of inefficient VS coupling mechanism by VSD; designing suitable distribution systems for the compressed air and cooling water system.

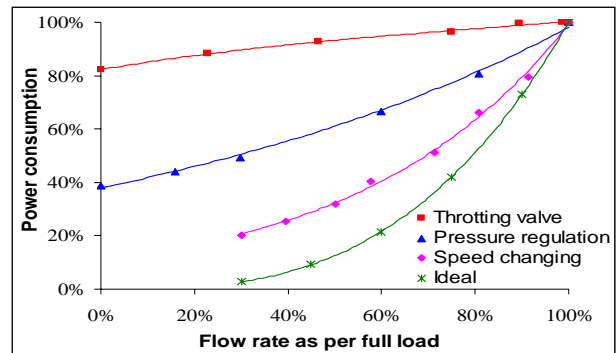

Figure 1. Power consumption vs. mode of operation

In the case of prime movers for extrusion molding machines, the power consumption of the motor using this technology varies linearly with the speed. An AC motor fitted with a VSD can control speed as precisely as a DC motor but requires less operating and maintenance costs.

The flow rate of water reduces linearly with the reduction in the shaft speed of the pump. However, the pump power is theoretically proportional to the cube of its speed. Figure 1 shows the variation in power consumption in the case of a water pumping system with three different modes of control.

Energy conservation

Prime mover in Tan Dai Hung Plastic

The Tan Dai Hung Plastic Company has six molding machines, four of which are equipped with VS coupling mechanism for controlling speed. The present operation shows these VS coupling motors are wasting significant amount of power (23-73%), equivalent to 5.2– 14.6 kW. This represents 3.2-9.1 MWh/month (2.5–7.2 million VND). Moreover, the temperature of the ventilation air leaving the VS coupling mechanism is very high, around 55°C, causing the working environment to be hot.



VS coupling-motor in extrusion molding machine



Option suggested for implementation

A motor incorporating a variable speed drive (VSD-inverter) will help overcome these problems as VSD consumes only a small fraction of the total power required.



Motor controlled by VSD after replacement



A 37kW motor coupled with VSD was used to replace the present 45kW-VS coupled motor in one machine. This was implemented in June 2002

thanks to the collaboration between the VSD supplier and the factory personnel.

This retrofit has helped to reduce the specific energy consumption (SEC) of the machine from 0.96 to 0.68 kWh/kg (reduction of 28%). The power demand of the machine has been lowered by 17.3kW.

Water system in Saigon Plastic

The Saigon Plastic Company has 9 injection molding machines. The present design includes 18 different cooling water systems, as shown in Figure 2. All pumps are housed in one room for ease of management. The integration of all machines has led to complicated layout, leakages, low reliability and poor performance.

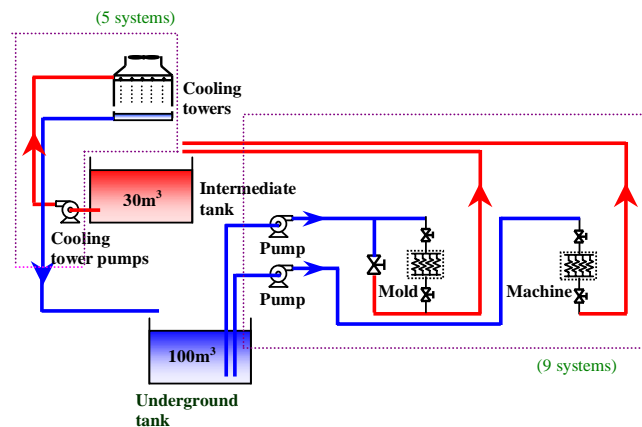

Figure 2. Schematic of the present cooling water system in Saigon Plastic

The use of VSD can help simplify the present system and provide better economic benefits. An experimental model of the proposed system was set up to test its performance. Figure 3 shows the schematic diagram of the proposed system.

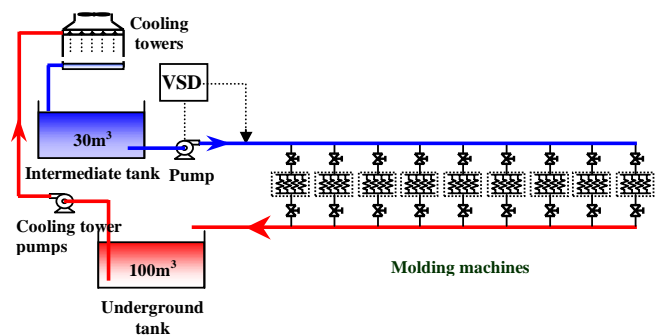

Figure 3. Schematic of the proposed cooling water system in Saigon Plastic

Cost - benefit

The cost of VSD for the prime mover of the extrusion molding machine includes the cost of VSD and other accessories.

The benefit from the retrofit is in the form of cost saving based on the reduction in electricity consumption. An indirect benefit is the improved working condition. The cost-benefit details of this Cleaner production option in Tan Dai Hung Plastic and Saigon Plastic factories are summarised below:

Details	Tan Dai Hung	Saigon*
Investment (million VND)	37	77.6
Savings (energy) (MWh/month)	10.8	9.7
Savings (costs) (million VND/month)	8.6	7.7
Payback period (months)	4.5	10

Note: 1US\$ = 15,300 VND (August 2002)

*Estimated

Comments

Mr. Nguyen Thanh Dung
Engineer,
Tan Dai Hung Plastic



VS coupling mechanism caused high power consumption and high temperature of exhausted ventilation air. Thanks to the use of VSD, these drawbacks have been overcome. Based on the success of this demonstration project, we are planning to replace all the remaining VS coupling mechanism by VSD. This is also a means for us to target the objectives of maintaining ISO 9002.

Contact

For more information, please contact:

❖ Department of Science, Technology and the Environment (DOSTE) of Ho Chi Minh City

244 Dien Bien Phu street, Dist. 3

Ho Chi Minh City, Vietnam

Tel: (84-8) 8242709 / 9320122

Fax: (84-8) 8242711

Email: pqlmt@hcm.vnn.vn

Technical support was provided by:

❖ Energy Conservation, Research and Development Center (ENERTEAM)
273 Dien Bien Phu street, Dist. 3
Ho Chi Minh City, Vietnam
Tel: (84-8) 9 302 393 / 9 307 350
Fax: (84-8) 9 307 350
Email: enerTEAM@fmail.vnn.vn

❖ Institute of Environment and Resource-National University-Ho Chi Minh City (CEFINEA)
142 To Hien Thanh Street, District 10
Ho Chi Minh City, Vietnam
Tel: (84-8) 8 651 132
Fax: (84-8) 8 655 670
Email: dan-np@hcm.vnn.vn

ABOUT THE PROJECT

- The Cleaner Production project in HCMC funded by the French Agency for the Environment and Energy Management (ADEME) was aimed at
 - reducing energy consumption and pollution in industrial sectors and
 - enhancing local technical and managerial capacity to deal with the energy-environment issues faced by the industries.
- The Department of Science, Technology and the Environment (DOSTE) of Ho Chi Minh City implemented the project with technical support from ENERTEAM and CEFINEA, and with guidance from experts of the Asian Institute of Technology (AIT). The plastic and the seafood industries were targeted. The project was initiated in September 2001.
- The methodology adopted to carry out the project was as follows:
 - Project initiation workshop
 - Preliminary survey to identify the current status of the industries.
 - Discussion with factories, and carrying out audits in selected factories to identify options.
 - Implementation of suggested options.
 - Preparation of fact sheets of viable options and detailed reports.
 - Final workshop (August 2002) to highlight and disseminate the findings.
- It is believed that the results of the project can be used as references for similar improvements in other factories.